



Wireless health monitoring and controlling using ZIGBEE

Dr. Nikhil Raj¹, Dr. M. Thamarai², Dr. Ganapathi sridhar³, Dr. D. Kiran⁴, Dr. Kishor Krishna kumar⁵
^{1,2,3,4}Professor, ⁵Asst. professor, Dept. of ECE, MRCE, Hyderabad

Abstract— Remote health care monitoring system (RHCMS) has drawn considerable attentions for the last decade. As the aging population is increasing and at the same time the health care cost is skyrocketing there has been a need to monitor a patient from a remote location. Moreover, many people of the World are out of the reach of existing health- care systems. To solve these problems many research and commercial versions of RHCMS have been proposed and implemented till now. In these systems the performance was the main issue in order to accurately measure, record, and analyze patients' data. With the ascent of wireless network RHCMS can be widely deployed to monitor the health condition of a patient inside and outside of the hospitals. In this work we present a ZigBee based wireless healthcare monitoring system that can provide real time online information about the health condition of a patient. The proposed system is able to send alarming messages to the healthcare professional about the patient's critical condition. In addition the proposed system can send reports to a patient monitoring system, which can be used by the healthcare professionals to make necessary medical advices from anywhere of the World at any time.

Keywords: ARM processor, ZIGBEE module, heartbeat sensor, temperature sensor, LED's, and LCD.

Introduction

Over the recent years remote health care monitoring systems for the elderly people have drawn considerable attentions. According to UNFPA, the global population is no longer young for the first time in the history [1].

Population ageing is affecting the entire world and is happening in all regions. But, it is progressing at a faster rate in the developing countries. Seven out of the fifteen countries in the developing world have more than 10 million old people. By the year 2050 another fifteen developing countries are expected to have 10 million old people.

It is worthwhile to mention here that the average life expectancy in the United States was 47.3 years in 1900. But, it has increased to 68.2 years and 77.3 years in 1950 and

2002 respectively [2, 3]. People are living longer because of better nutrition, sanitation, medical advances, education, economic well-being, and health care. Population ageing poses challenges to individuals, families, and societies.

By adopting proper policies societies should be prepared for an ageing world. Overall, the older people should not be considered as a burden for the society. Their wisdom, energy, and experience are added advantages for us to take care of the challenges of the 21st century. In order to keep the ageing population healthy we have to deal with some challenges. The major challenge for us is to keep them healthy with our limited resources.

II. RELATED WORK:

ARM PROCESSOR:

The ARM7TDMI-S is a general purpose 32-bit micro-processor, which offers high performance and very low power consumption. The ARM architecture is based on Reduced Instruction Set Computer (RISC) principles, and the instruction set and related decode mechanism are much simpler than those of micro programmed Complex Instruction Set Computers (CISC). This simplicity results in a

high instruction throughput and impressive real-time interrupt response from a small and cost-effective processor core. Pipeline techniques are employed so that all parts of the processing and memory systems can operate continuously.

Typically, while one instruction is being executed, its successor is being decoded, and a third instruction is being fetched from memory. The ARM7TDMI-S processor also employs a unique architectural strategy known as Thumb, which makes it ideally suited to high-volume applications with memory restrictions, or applications where code density is an issue. The key idea behind Thumb is that of a super reduced instruction set.

ZIGBEE MODULE:

Zig Bee is a low-cost, low-power, wireless mesh networking proprietary standard. The low cost allows the technology to be widely deployed in wireless control and monitoring

applications, the low power-usage allows longer life with smaller batteries, and the mesh networking provides high reliability and larger range. The ZigBee Alliance, the standards body that defines ZigBee, also publishes application profiles that allow multiple OEM vendors to create interoperable products.

The protocols build on recent algorithmic research (Ad-hoc On-demand Distance Vector, neuron) to automatically construct a low-speed ad-hoc network of nodes. In most large network instances, the network will be a cluster of clusters. It can also form a mesh or a single cluster. The current profiles derived from the ZigBee protocols support beacon and non-beacon enabled networks.

Transmitter Section:

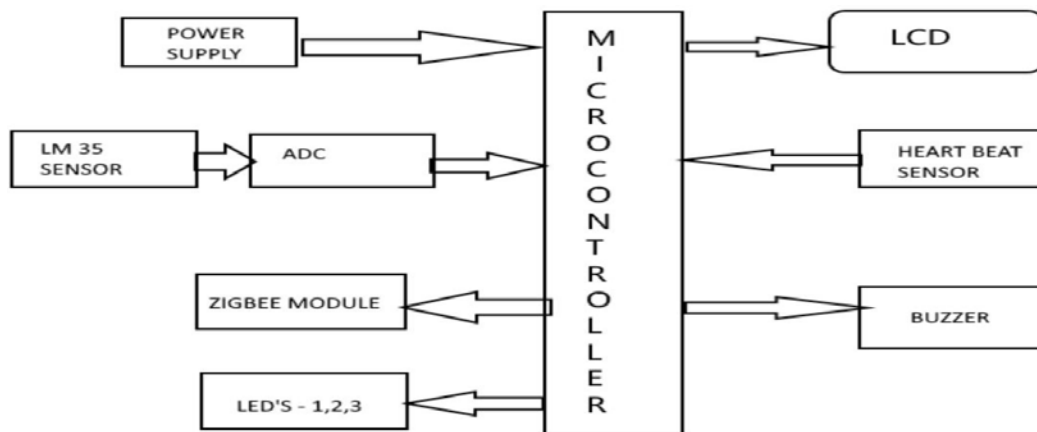

Figure-1: Block diagram of Patient Section

Receiver Section:



Figure-2: Block diagram of Doctor Section

III. SENSORS:

TEMPERATURE SENSOR (LM35)

LM35 is a precision IC temperature sensor with its output proportional to the temperature (in oC). The sensor circuitry is sealed and therefore it is not subjected to oxidation and other processes. With LM35, temperature can

be measured more accurately than with a thermistor. It also possesses low self-heating and does not cause more than 0.1 oC temperature

rise in still air. The operating temperature range is from - 55°C to 150°C. The output voltage varies by 10mV in response to every oC rise/fall in ambient temperature, i.e., its scale factor is 0.01V/ oC.

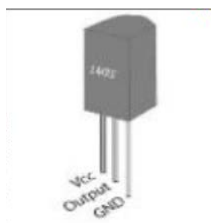

Figure-3: temperature sensor

HEARTBEAT SENSOR:

Modern heart rate monitors usually comprise two elements: a chest strap transmitter and a wrist receiver (which usually doubles as a watch) or mobile phone. In early plastic straps, water or liquid was required to get good performance. Later units have used conductive smart fabric with built-in microprocessors that analyze the EKG signal to determine heart rate. Strapless heart rate monitors now allow the user to just touch two sensors on a wristwatch display for a few seconds to view heart rate data. These are popular for comfort and ease of use, though they don't give as much detail as monitors that use a chest strap. More advanced models offer measurements of heart rate variability, activity, and breathing rate to assess parameters relating to a subject's fitness. Sensor fusion algorithms allow these monitors to detect core temperature and dehydration. Another style of heart rate monitor replaces the plastic around-the-chest strap with fabric sensors - the most common of these is a sports bra for women that include sensors in the fabric.

IV. RESULTS:

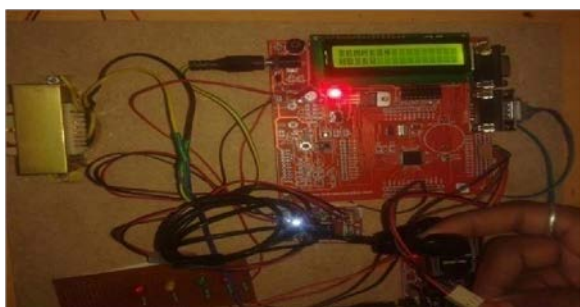

Figure-5: Sensors output values on PC

V. CONCLUSION:

With the fast development of the industrialization and urbanization process in the world and hence with the increase of busyness of people it has become difficult to monitor the health conditions of a patient continuously. Also

with the increase in the number senior citizens and chronic diseases, the number of elderly patients who need constant assistance has increased. One key point of all critical care for elderly patient is the continuous monitoring of their vital signs. To avoid unexpected health problems and obtain higher accuracy in diagnosis of the health conditions of a patient, efficient and comprehensive data collecting, monitoring and control play an important role to improve the health care system more reliable and effective.

REFERENCES

- [1] Mohamed Fezari, Mounir Bousbia- Salah, "Microcontroller Based Heart Rate Monitor", the International Arab Journal of Information Technology, Vol. 5, No. 4, October 2008.
- [2] S.Josephine Selvarani, „Online Health Monitoring System Using Zigbee“, International Journal on Computer Science and Engineering, Vol. 3 No. 4 Apr 2011.
- [3] Muzhir Shaban Al-Ani, „The Mechanism of Monitoring and Tracking of Healthcare Systems“, J. Of university of anbar for pure science : Vol.6:NO.2 : 2012.
- [4] Ankush Nayyar, Hemant Lenka, „Design And Development Of Wrist-Tilt Based Pc Cursor Control Using Accelerometer“, IJCSEA Vol.3, No.4, August 2013.
- [5] Marci Meingast, Tanya Roosta, Shankar Sastry, “Security and Privacy Issues with Health Care Information Technology”, IEEE, 2006.
- [6] Shobaranimada, Sandhyarani.S, “An Adaptive embedded system for helping patients”, International Journal of Computer Trends and Technology, volume2, 2011.
- [7] B.Chiranjeevini Kumari, K.Rajasekar, “Implementation of SMS based Heartbeat Monitoring System using psoc Microcontroller”, International Journal of electronics & communication technology, Volume -2, 2011.
- [8] Ms.Kadam Patil D. D. And Mr.Shastri R. K., “Design of Wireless Electronic Stethoscope Based on Zig-Bee”, International Journal of Distributed and Parallel Systems, Volume -3, 2012.
- [9] V.Ramya, Anuradha Kumari, “Embedded Intensive Patient Care Unit”, David Bracewell, et al. (Eds): AIAA 2011, CS & IT 03, pp. 169–176, 2011.
- [10] T. Murugan, Azha.Periasamy, Embedded based Industrial Temperature Monitoring Systems using GSM“, International Journal of Computer Applications Volume 58– No.19, November 2012
- [11] Shaojie Lin, Qiong Liu, Xi- aoming Wu, Shanglin Li and Zhicong Zhao, “Wireless monitoring system via Zig-Bee in ICUs”, IFMBE Proceedings, Volume - 19,2008.